



(19) **United States**

(12) **Patent Application Publication**
CHO et al.

(10) **Pub. No.: US 2019/0288212 A1**
(43) **Pub. Date: Sep. 19, 2019**

(54) **ORGANIC LIGHT-EMITTING DIODE
DEVICE AND COMPOUND FOR CHARGE
GENERATION LAYER INCLUDED THEREIN**

Publication Classification

(71) Applicant: **Samsung Display Co., Ltd.**, Yongin-si (KR)

(51) **Int. Cl.**
H01L 51/00 (2006.01)
C07F 5/02 (2006.01)
(52) **U.S. Cl.**
CPC *H01L 51/0051* (2013.01); *H01L 51/5278*
(2013.01); *H01L 51/008* (2013.01); *C07F*
5/025 (2013.01)

(72) Inventors: **Yoonhyeung CHO**, Yongin-si (KR);
Hyungseok JANG, Hwaseong-si (KR);
Dongchan KIM, Gunpo-si (KR);
Wonjong KIM, Suwon-si (KR);
Jiyoung MOON, Gwangju-si (KR);
Yeongrong PARK, Osan-si (KR);
Dongkyu SEO, Suwon-si (KR);
Myungchul YEO, Asan-si (KR); **Jihye**
LEE, Incheon (KR)

(57) **ABSTRACT**

Disclosed is an organic light-emitting diode device including: a first electrode; a second electrode disposed opposite to the first electrode; m light-emitting units (where m is an integer of 2 or more) disposed between the first electrode and the second electrode, and including at least one light-emitting layer; and m-1 charge generation layers each interposed between two adjacent light-emitting units of the m light-emitting units; wherein at least one of the m-1 charge generation layers includes a compound for a charge generation layer, which includes a boron-containing compound bonded to a metal halide by a one-electron sigma bond.

(21) Appl. No.: **16/206,969**

(22) Filed: **Nov. 30, 2018**

(30) **Foreign Application Priority Data**

Mar. 13, 2018 (KR) 10-2018-0029112

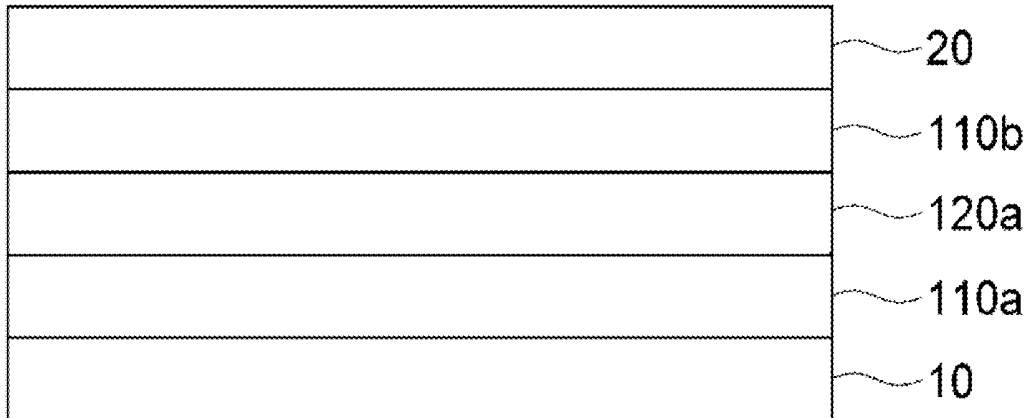

FIG. 1

100

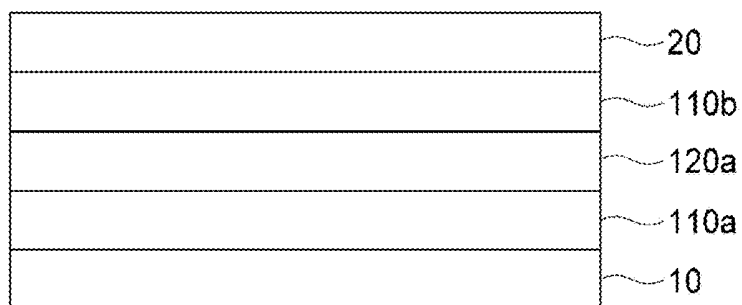

FIG. 2

100

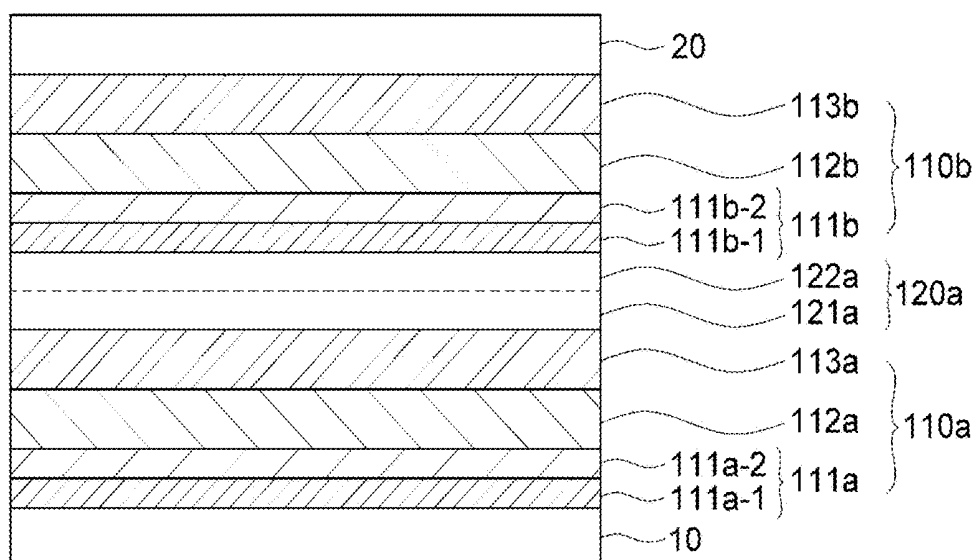

FIG. 3

200

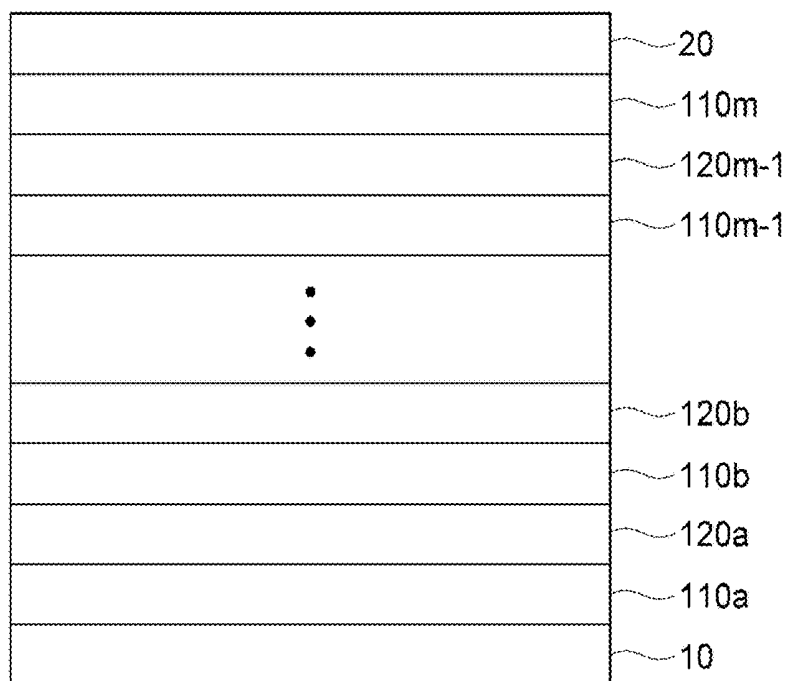

FIG. 4

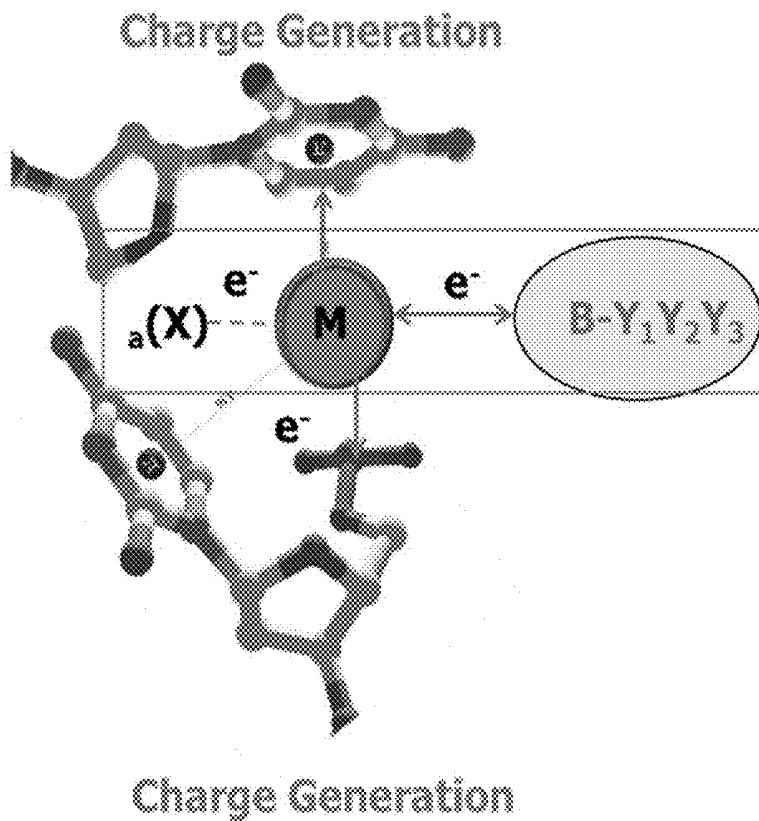
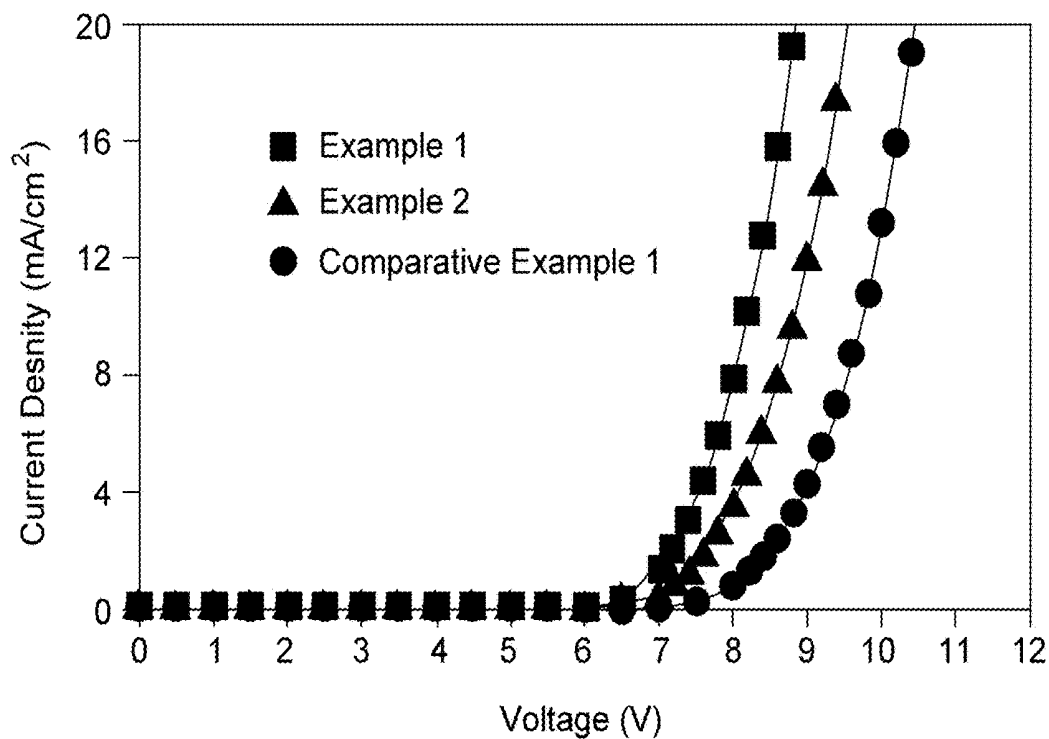

FIG. 5



**ORGANIC LIGHT-EMITTING DIODE
DEVICE AND COMPOUND FOR CHARGE
GENERATION LAYER INCLUDED THEREIN**

CROSS-REFERENCE TO RELATED
APPLICATION

[0001] This application claims priority to and the benefit of Korean Patent Application No. 10-2018-0029112, filed on Mar. 13, 2018, in the Korean Intellectual Property Office (KIPO), the entire content of which is incorporated herein by reference.

BACKGROUND

1. Field

[0002] Exemplary embodiments of the present disclosure relate to an organic light-emitting diode device having low driving voltage, high efficiency, and long lifespan characteristics, and a compound for a charge generation layer included in the device, which has excellent charge-generation ability and charge-transfer ability.

2. Discussion of Related Art

[0003] An organic light-emitting display device is a self-luminescent display device that displays images by means of a plurality of organic light-emitting diodes configured to emit light. This organic light-emitting display device exhibits characteristics, such as low power consumption, high luminance, and high response speed, and is thus currently attracting attention as a display device.

[0004] Generally, an organic light-emitting diode includes an anode and a cathode disposed opposite to each other, and at least one organic light-emitting layer disposed between the anode and the cathode. The organic light-emitting diode device uses the principle that holes and electrons generated from the anode and the cathode, respectively, are injected into the organic light-emitting layer and combine to generate excitons and light is emitted when the excitons decay (e.g., transition or relax) to a ground state. The organic light-emitting diode device may include, in addition to the organic light-emitting layer disposed between the anode and the cathode, a hole transport layer, an electron injection layer, an electron transport layer, etc.

[0005] Such light-emitting devices are classified, according to a method of configuring the organic light-emitting layer, into a single type (or single kind) of light-emitting device including a single organic light-emitting layer, and a tandem type (or tandem kind) of light-emitting device including two or more organic light-emitting layers arranged in a tandem configuration. Among them, the tandem-type (or tandem kind) of organic light-emitting diode device has features relative to the single type (or single kind) of organic light-emitting diode device in terms of increased efficiency, high stability, a long lifespan and the like, and thus may be used in display devices or lighting devices which require high luminance and a long lifespan. To realize this tandem-type (or tandem kind) of organic light-emitting diode device, a charge generation layer (CGL) that couples (or connects) two or more organic light-emitting layers is present in the device.

[0006] However, a conventional charge generation layer is problematic in that it increases the driving voltage of the tandem-type (or tandem kind) of light-emitting device by

about 1.3-2 times or more compared to that of a conventional single-type (or single kind) of organic light-emitting diode device due to its poor ability to generate and transfer charges, thus reducing the power efficiency and lifespan of the organic light-emitting diode device. To solve this problem, it is important to select materials and elements so that electron tunneling at the interface is possible.

SUMMARY

[0007] Exemplary embodiments of the present disclosure are directed to an organic light-emitting diode device having low driving voltage, high efficiency, and long lifespan characteristics by including a charge generation layer having an excellent ability to generate and transfer charges.

[0008] According to an exemplary embodiment of the present disclosure, there is provided an organic light-emitting diode device including: a first electrode; a second electrode disposed opposite to the first electrode; m light-emitting units (where m is an integer of 2 or more) disposed between the first electrode and the second electrode, and including at least one light-emitting layer; and m-1 charge generation layers each interposed between two adjacent light-emitting units of the m light-emitting units; wherein at least one of the m-1 charge generation layers includes a compound represented by Formula 1 below:

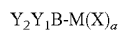

Formula 1

[0009] wherein:

[0010] M is a metal selected from the group consisting of Group 1 metals, Group 2 metals, transition metal, post-transition metals, lanthanides, and actinides, which have a work function of 4.0 eV or less;

[0011] X is a halogen element selected from the group consisting of F, Cl, Br, and I;

[0012] a is a natural number ranging from 1 to 4; and

[0013] Y_1 and Y_2 are the same or different, and are each independently one or more selected from the group consisting of a halogen, a hydroxyl group, a nitro group, a cyano group, an amine group, a C_1-C_{40} alkyl group, a C_6-C_{40} aryl group, and a 5- to 40-membered heteroaryl group, or they may be bonded to an adjacent group to form a condensed ring, provided that at least one of Y_1 and Y_2 is a C_6-C_{40} aryl group or a 5- to 40-membered heteroaryl group; and

[0014] wherein the alkyl group, the aryl group, and the heteroaryl group are each unsubstituted or substituted with one or more substituents selected from the group consisting of a halogen, a cyano group, a nitro group, a C_1-C_{40} alkyl group, a C_6-C_{40} aryl group, a 5- to 40-membered heteroaryl group, a C_6-C_{40} aryloxy group, a C_6-C_{40} arylphosphine oxide group, and a C_6-C_{40} arylamine group, and the substituents may be the same or different if they are plural in number.

[0015] The compound represented by formula 1 may be a charge transfer (CT) complex comprising a boron-containing compound and a metal halide.

[0016] The content ratio between the boron-containing compound and the metal halide may be 0.5-50:50-95.5 by weight.

[0017] The compound represented by formula 1 may be bonded to adjacent compounds of formula 1 to form a cluster, and the cluster may include at least one heterocyclic ring containing the boron and the metal (M).

[0018] Each of the m-1 charge generation layers may include at least one host and at least one dopant, and one of

the at least one host and at least one dopant may be the compound represented by formula 1.

[0019] The m light-emitting units may be disposed alternately with the $m-1$ charge generation layers, and two light-emitting units of the m light-emitting units may be disposed adjacent to the first electrode and the second electrode, respectively.

[0020] Each of the m light-emitting units may include a hole transport region, a light-emitting layer and an electron transport region, the hole transport region may include at least one of a hole injection layer and a hole transport layer, and the electron transport region may include at least one of an electron transport layer and an electron transport layer.

[0021] Each of the $m-1$ charge generation layers may include an n-type charge generation layer and a p-type charge generation layer, the n-type charge generation layer may be disposed adjacent to the electron transport region of each of the m light-emitting units, and the p-type charge generation layer may be disposed adjacent to the hole transport region of each of the m light-emitting units.

[0022] The n-type charge generation layer may include a metal selected from the group consisting of Group 1 metals, Group 2 metals, lanthanides, and actinides, which have a work function of 4.0 eV or less.

[0023] The p-type charge generation layer may include a metal selected from the group consisting of transition metals and post-transition metals, which have a work function of 4.0 eV or less.

[0024] According to another exemplary embodiment of the present disclosure, there is provided a compound for a charge generation layer, including: at least one boron-containing compound; and at least one metal halide containing a metal having a work function of 4.0 eV or less; wherein the boron (B) of the boron-containing compound and the metal (M) of the metal halide are bonded to each other by a one-electron sigma (σ) bond.

[0025] In the compound for the charge generation layer, the bonding value between the metal (M) and boron (B), which is measured by X-ray photoelectron spectrometry (XPS), may range from 180 to 290 eV.

[0026] The metal halide may be a metal iodide.

[0027] The compound for the charge generation layer may be used for an n-type charge generation layer, a p-type charge generation layer, or both.

[0028] The n-type charge generation layer may include a metal selected from the group consisting of Group 1 metals, Group 2 metals, lanthanides, and actinides, which have a work function of 4.0 eV or less.

[0029] The p-type charge generation layer may include a metal selected from the group consisting of transition metals and post-transition metals, which have a work function of 4.0 eV or less.

[0030] The compound for the charge generation layer may be a charge-transfer (CT) complex comprising a boron-containing compound and a metal halide.

[0031] In the compound for the charge generation layer, the content ratio between the boron-containing compound and the metal halide may be 0.5-50: 50-95.5 by weight.

[0032] The compound for the charge generation layer may be bonded to adjacent compounds of formula 1 to form a cluster, and the cluster may include at least one heterocyclic ring containing the boron and the metal (M).

BRIEF DESCRIPTION OF THE DRAWINGS

[0033] The patent or application file contains at least one drawing executed in color. Copies of this patent or patent application publication with color drawing(s) will be provided by the Office upon request and payment of the necessary fee.

[0034] A more complete appreciation of the present disclosure will become more apparent by describing in more detail exemplary embodiments thereof with reference to the accompanying drawings, wherein:

[0035] FIG. 1 is a cross-sectional view showing the structure of an organic light-emitting diode device according to an exemplary embodiment of the present disclosure;

[0036] FIG. 2 is an enlarged cross-sectional view showing the structure of the organic light-emitting diode device shown in FIG. 1;

[0037] FIG. 3 is a cross-sectional view showing the structure of an organic light-emitting diode device according to another exemplary embodiment of the present disclosure;

[0038] FIG. 4 is a schematic view showing the charge-generation mechanism of a compound for a charge generation layer according to the present disclosure; and

[0039] FIG. 5 is a graph showing changes in the driving voltages of organic light-emitting diode devices fabricated in Examples 1 and 2 and Comparative Example 2.

DETAILED DESCRIPTION

[0040] Features of the present disclosure and methods for achieving them will become apparent from exemplary embodiments described below in more detail in conjunction with the accompanying drawings. However, the present disclosure is not limited to the following exemplary embodiments, but is embodied in various different forms. These exemplary embodiments are provided merely to make the present disclosure complete and fully convey the scope of the present disclosure to a person having ordinary knowledge in the art to which the present disclosure pertains. The present disclosure is defined only by the scope of the attached claims, and equivalents thereof. Therefore, in some exemplary embodiments, well-known process steps, device structures, and technologies are not described in more detail in order to prevent the present disclosure from being obscurely interpreted. Throughout the specification, the same reference symbols refer to the same components.

[0041] Unless otherwise defined, all terms used herein (including technical and scientific terms) will have the same meanings as commonly understood by a person having ordinary knowledge in the art to which the present disclosure pertains. Terms, such as those defined in commonly used dictionaries, should not be interpreted in ideal or excessively formal senses unless clearly and particularly defined.

[0042] An exemplary embodiment of the present disclosure is directed to a charge-transfer complex compound which may be used as a material for a charge generation layer (CGL).

[0043] The charge generation layer (CGL) refers to a layer configured to separate adjacent light-emitting units without being in direct contact with both electrodes (e.g., a first electrode, and a second electrode) in an organic light-emitting diode device including a plurality of light-emitting units. This charge generation layer is disposed between two adjacent light-emitting units, and functions as a cathode

(that generates electrodes) for one of the two light-emitting units and as an anode (that generates holes) for the other light-emitting unit. A material for this charge generation layer should have the ability to generate and transfer charges.

[0044] A compound for a charge generation layer according to the present disclosure includes: at least one boron-containing compound; and at least one metal halide containing a metal having a work function of 4.0 eV or less. The boron (B) of the boron-containing compound and the metal (M) of the metal halide are bonded to each other by a one-electron sigma bond (a).

[0045] As shown in FIG. 4, in the charge-transfer complex compound, a halogen and boron (B) bonded (or connected) to both sides of a metal (M), respectively, all exhibit electron-attracting properties. Accordingly, each of the halogen atom (X) and boron (B) in the molecule functions as an electron acceptor while the metal (M) functions as an electron donor, and thus spontaneous charge polarization between the two atom groups in one molecule occurs leading to charge transfer. When the metal (M) used in the charge-transfer complex compound is an n-type metal having a high Fermi level, charge generation and transfer may be more efficient. Having such charge generation and transfer characteristics, the compound may be a material for a charge generation layer (CGL) in a tandem type (or tandem kind) of light-emitting device.

[0046] In the charge-transfer complex compound, the sigma bond between the boron (B) and the metal (M) may be examined by X-ray photoelectron spectrometry (XPS), ultraviolet photoelectron spectrometry (UPS), or the like. For example, in the charge-transfer complex compound of the present disclosure, the bonding value between the metal (M) and the boron (B) may range from 180 to 290 eV, as measured by XPS. Such XPS may be performed under a vacuum condition.

[0047] The compound for the charge generation layer may be represented by Formula 1 below:



[0048] wherein:

[0049] M is a metal selected from the group consisting of Group 1 metals, Group 2 metals, transition metal, post-transition metals, lanthanides, and actinides, which have a work function of 4.0 eV or less;

[0050] X is a halogen element selected from the group consisting of F, Cl, Br, and I;

[0051] a is a natural number ranging from 1 to 4; and

[0052] Y_1 and Y_2 are the same or different, and are each independently one or more selected from the group consisting of a halogen, a hydroxyl group, a nitro group, a cyano group, an amine group, a C_1 - C_{40} alkyl group, a C_6 - C_{40} aryl group, and a 5- to 40-membered heteroaryl group, or they may be bonded to an adjacent group to form a condensed ring (or a fused ring), provided that at least one of Y_1 and Y_2 is a C_6 - C_{40} aryl group or a 5- to 40-membered heteroaryl group.

[0053] In this case, the alkyl group, the aryl group, and the heteroaryl group are each unsubstituted or substituted with one or more substituents selected from the group consisting of a halogen, a cyano group, a nitro group, a C_1 - C_{40} alkyl group, a C_6 - C_{40} aryl group, a 5- to 40-membered heteroaryl group, a C_6 - C_{40} aryloxy group, a C_6 - C_{40} arylphosphine

oxide group, and a C_6 - C_{40} arylamine group, and the substituents may be the same or different if they are plural in number.

[0054] In the compound represented by formula 1, BY_1Y_2 is a moiety derived from a boron-containing compound, and $M(X)_a$ represents a metal halide.

[0055] According to an exemplary embodiment of the present disclosure, X in formula 1 may be iodine (I), and the metal (M) may be one or more selected from the group consisting of Li, Na, K, Rb, Cs, Be, Mg, Ca, Sr, Ba, La, Ce, Pr, Nd, Pm, Sm, Eu, Gd, Tb, Dy, Ho, Er, Tm, Yb, Lu; Ag, Au, B, Be, C, Co, Cr, Cu, Fe, Hg, Ir, Mo, Nb, Ni, Os, Pd, Pt, Re, Rh, Ru, Sb, Se, Si, Sn, Ta, Te, Ti, V, W and Zn.

[0056] According to another exemplary embodiment of the present disclosure, one of Y_1 and Y_2 in formula 1 may be a C_6 - C_{40} aryl group or a 5- to 40-membered heteroaryl group. For example, it may be a 5- to 40-membered heteroaryl group containing at least one N atom, which is a nitrogen-containing group. This nitrogen-containing group makes it possible to control hole mobility.

[0057] In this case, the nitrogen-containing group may be a 5-membered aromatic ring group, a 6-membered aromatic ring group, or a 9-membered aromatic ring group including a 5-membered aromatic group fused to a 6-membered aromatic group. In one example, the nitrogen-containing group may be one or more selected from the group consisting of substituents represented by structural formulas below, but is not particularly limited thereto:

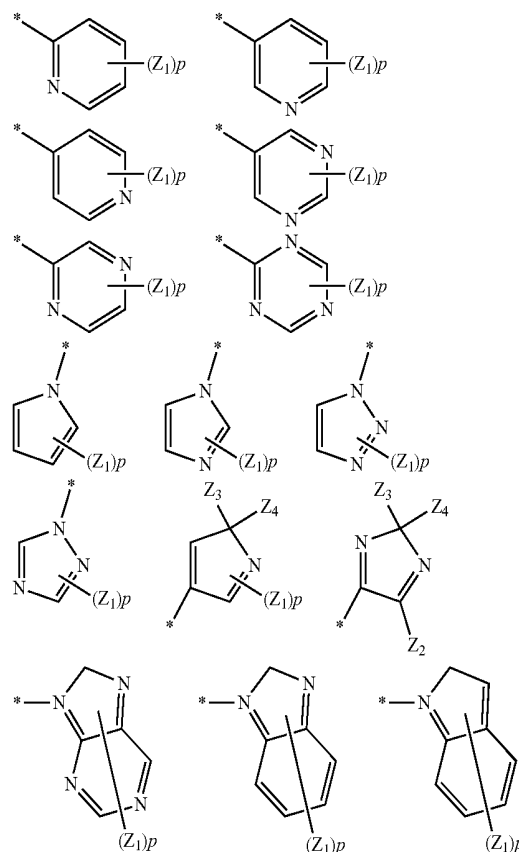

-continued

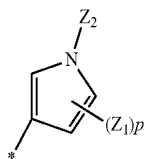

[0058] wherein:

[0059] Z_1 to Z_4 are the same or different, and are each independently selected from the group consisting of hydrogen, deuterium, a halogen, a hydroxyl group, a cyano group, a nitro group, an amino group, an amidino group, hydrazine, hydrazone, a carboxyl group, a sulfonic acid group, and a C_1 - C_6 alkyl group; and p is an integer ranging from 1 to 6, and if p is an integer of 2 or more, a plurality of Z_1 may be the same or different.

[0060] The compound for the charge generation layer according to the present disclosure may be produced using a boron-containing compound and a metal halide according to any suitable method available in the art. In one example, it may be formed by co-depositing a boron-containing compound and a metal halide. In such co-deposition, the mixing ratio between the boron-containing compound and the metal halide is not particularly limited. In one example, the content ratio between the boron-containing compound and the metal halide may be 0.5-50: 50-99.5 by weight, for example, 1.0-30: 70-99.0 by weight.

[0061] In one example, the boron-containing compound and the metal halide may be represented by Formulas 2 and 3 below:

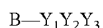

Formula 2

[0062] wherein:

[0063] Y_1 and Y_2 are as defined in Formula 1 above; and

[0064] Y_3 is one or more selected from the group consisting of a halogen, a hydroxyl group, a nitrogen group, a cyano group, an amine group, a C_1 - C_{40} alkyl group, a C_6 - C_{40} aryl group, and a 5- to 40-membered heteroaryl group.

[0065] In this case, the alkyl group, the aryl group, and the heteroaryl group are each unsubstituted or substituted with one or more substituents selected from the group consisting of a halogen, a cyano group, a nitro group, a C_1 - C_{40} alkyl group, a C_6 - C_{40} aryl group, a 5- to 40-membered heteroaryl group, a C_6 - C_{40} aryloxy group, a C_6 - C_{40} arylphosphine oxide group, and a C_6 - C_{40} arylamine group, and if the substituents are plural in number, they may be the same or different;



Formula 3

[0066] wherein M and a are as defined in Formula 1 above.

[0067] When the boron-containing compound of formula 2 and the metal halide of formula 3 are co-deposited, any one (e.g., Y_3) of groups constituting the boron-containing compound [$BY_1Y_2Y_3$] is detached while the boron (B) of the boron-containing compound forms a single sigma (σ) bond with the metal (M) of the metal halide. In this case, although the group which is detached from the boron-containing compound is represented by Y_3 for convenience, it is not particularly limited thereto and the kind and position of group which is detached from boron-containing compound may vary

[0068] Meanwhile, the charge generation layer (CGL) needs to inject or transport electrons into one of two adjacent light-emitting units, and inject or transport holes into the

other one. As described above, the charge generation layer includes a charge generation layer having n-type properties (an 'n-type charge generation layer') and a charge generation layer having p-type characteristics (a 'p-type charge generation layer'). Thus, the compound for the charge generation layer according to the present disclosure may be used for an n-type charge generation layer, a p-type charge generation layer, or both. In addition, the compound for the charge generation layer may be used as a host or dopant that constitutes each of the n-type charge generation layer and the p-type charge generation layer.

[0069] According to an exemplary embodiment of the present disclosure, the compound of formula 1, which is included in the n-type charge generation layer, may include a first metal (M_1) selected from the group consisting of Group 1 metals, Group 2 metals, lanthanides, and actinides, which have a work function of 4.0 eV or less. For example, it may be a first metal iodide, such as, for example, one or more selected from the group consisting of LiI, NaI, KI, RbI, CsI, BeI_2 , MgI_2 , CaI_2 , SrI_2 , BaI_2 , YbI, YbI₂, YbI₃, and SmI_3 .

[0070] According to an exemplary embodiment of the present disclosure, the compound of formula 1, which is included in the p-type charge generation layer, may include a second metal (M_2) selected from the group consisting of transition metals and post-transition metals, which have a work function of 4.0 eV or less. For example, it may be a second metal iodide, such as, for example, one or more selected from the group consisting of CuI, TiI, AgI, CdI₂, HgI₂, SnI₂, PbI₂, BiI₃, ZnI₂, MnI₂, FeI₂, CoI₂, NiI₂, AlI₃, ThI₄, and UI₃. For example, the compound represented by formula 1 according to the present disclosure may be used for the p-type charge generation layer, because it has an excellent ability to generate and transfer holes.

[0071] The above-described compound for the charge generation layer according to the present disclosure may bond with adjacent compounds, for example, compounds of formula 1, and n-type or p-type materials which are used in combination therewith, thereby forming a more stable cluster. This cluster is not particularly limited with respect to its structure. In one example, it may include at least one heterocyclic ring containing the boron and the metal (M), which are located adjacent to each other. In this regard, the heterocyclic ring may refer to a 5- to 40-membered ring containing a heteroatom other than the boron and the metal (M), such as, for example, at least one nitrogen (N) atom.

[0072] In one example, the cluster formed from the compound of formula 1 may be represented by any one of Formulas 4 to 7 below, but is not particularly limited thereto:

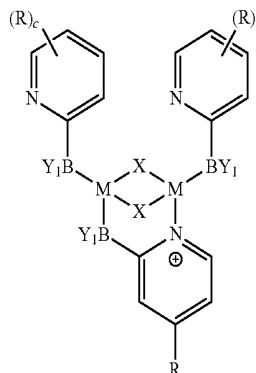

Formula 4

-continued

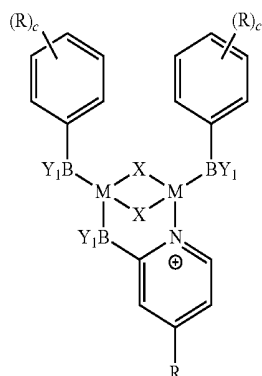

Formula 5

Formula 6

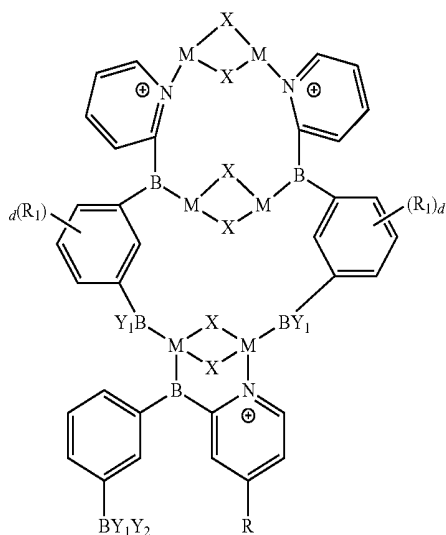

Formula 7

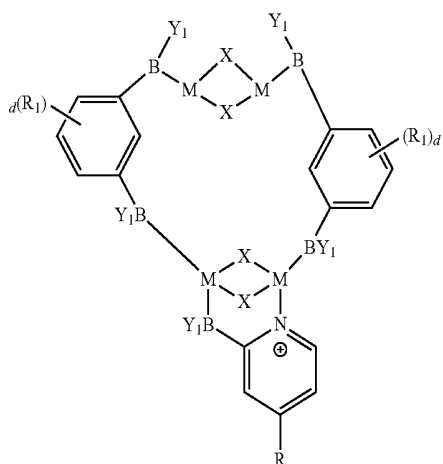

[0073] wherein:

[0074] R and R₁ are the same or different, and are each independently selected from the group consisting of hydrogen, deuterium, a halogen, a cyano group, a nitro group, a C₁-C₄₀ alkyl group, a C₆-C₆₀ aryl group, and a 5- to 60-membered heteroaryl group;

[0075] the alkyl group, the aryl group, and the heteroaryl group are each substituted with one or more substituents selected from the group consisting of a halogen, a cyano

group, a nitro group, a C₁-C₄₀alkyl group, a C₆-C₄₀ aryl group, a 5- to 40-membered heteroaryl group, a C₆-C₄₀ aryloxy group, a C₆-C₄₀ arylphosphine oxide group, and a C₆-C₄₀ arylamine group, and substituents may be the same or different if they are plural in number; and

[0076] c and d are each independently an integer ranging from 1 to 4.

[0077] As used herein, the term “alkyl” refers to a monovalent substituent derived from linear or branched saturated hydrocarbon of 1 to 40 carbon atoms, including, for example, methyl, ethyl, propyl, isobutyl, sec-butyl, pentyl, iso-amyl, hexyl, and the like.

[0078] As used herein, the term “aryl” denotes a monovalent substituent derived from an aromatic hydrocarbon of 6 to 60 carbon atoms with a single ring or a combination of two or more rings in which two or more rings may simply be pendant to each other or fused together, as exemplified by phenyl, naphthyl, phenanthryl, anthryl, etc.

[0079] As used herein, the term “heteroaryl” denotes a monovalent substituent derived from a mono- or polyheterocyclic aromatic hydrocarbon of 5 to 60 nuclear atoms in which at least one, for example, one to three, carbon atoms of the ring are substituted by a heteroatom such as N, O, S or Se. Two or more rings of the heteroaryl, if present, may simply be pendant to each other or fused together or to an aryl group. Examples include 6-membered monocyclic rings such as pyridyl, pyrazinyl, pyrimidinyl, pyridazinyl, and triazinyl, polycyclic rings such as phenoxathieryl, indoliziny, indolyl, purinyl, quinolyl, benzothiazole, and carbazolyl, 2-furanyl, N-imidazolyl, 2-ixosazolyl, 2-pyridinyl, and 2-pyrimidinyl.

[0080] As used herein, the term “condensed ring” or “fused ring” refers to a fused aliphatic ring, a fused aromatic ring, a fused heteroaliphatic ring, a heteroaromatic ring, or a combination thereof.

[0081] As described above, the compound represented by formula 1 according to the present disclosure has spontaneous charge transfer characteristics and material stability, due to sigma bond formation between boron and the metal halide, and structural specificity (e.g., a cluster). Accordingly, an organic light-emitting diode device including the above-described compound as the host and/or dopant of the charge generation layer may exhibit the properties of rapidly generating, transferring and separating charges, and thus may exhibit the effect of reducing the driving voltage without affecting the high efficiency and long lifespan characteristics.

[0082] Hereinafter, exemplary embodiments of the present disclosure will be described with reference to the accompanying drawings.

[0083] FIGS. 1-3 are cross-sectional views schematically showing the structure of an organic light-emitting diode device including at least one charge generation layer (CGL).

[0084] The organic light-emitting diode device may include: a first electrode; a second electrode disposed opposite to the first electrode; m light-emitting units (where m is an integer of 2 or more) disposed between the first electrode and the second electrode, and including at least one light-emitting layer; and m-1 charge generation layers each interposed between two adjacent light-emitting units of the m light-emitting units.

[0085] In this case, m may be an integer of 2 or more, for example, 2 to 10, 2 to 4, 2 or 3. An exemplary embodiment of an organic light-emitting diode device, where m is 2,

refers to FIGS. 1-2, and an exemplary embodiment of an organic light-emitting diode device, where *m* is 3 or more, refers to FIG. 3.

[0086] FIGS. 1-2 are cross-sectional views schematically showing the structure of an organic light-emitting diode device **100** according to a first exemplary embodiment of the present disclosure.

[0087] Referring to FIG. 1, the organic light-emitting diode device **100** includes a single charge generation layer (CGL). For example, it includes a first electrode **10**, a second electrode **20**, a first light-emitting unit **110a**, a second light-emitting unit **110b**, and a charge generation layer **120a**. In this case, the light-emitting unit refers to a unit having a function of emitting light, and includes at least one light-emitting layer that emits color light having a set (e.g., specific) wavelength.

[0088] Hereinafter, each component of the organic light-emitting diode device will be described in more detail.

First Electrode

[0089] The first electrode **10** is disposed on a substrate, and is electrically coupled to (e.g., electrically connected to) a driving thin film transistor so that it may receive a driving current from the driving thin film transistor. This first electrode **10** may include a material having a relatively high work function, and thus functions as an anode that injects holes into a hole transport region **111a** adjacent thereto. In this case, the second electrode **20** disposed opposite to the first electrode **10** functions as a cathode that injects electrons into an electron transport region **113b** adjacent thereto. However, the present disclosure is not limited thereto, and in some cases, the first electrode **10** may function as a cathode, and the second electrode **20** may function as an anode.

[0090] When the organic light-emitting diode device **100** is of a bottom emission type (or bottom emission kind), the first electrode **10** may include a material, such as ITO, IZO, ZnO or In₂O₃, or a stack including two or more of these materials.

[0091] On the other hand, when the organic light-emitting diode device **100** is of a top emission type (or top emission kind), the first electrode **10** may further include a silver (Ag)-based reflective layer having high reflectivity. According to one exemplary embodiment, the first electrode **10** has an at least two-layer structure including a silver (Ag)-based reflective layer and a transparent conductive layer disposed on the reflective layer. According to another exemplary embodiment, the first electrode **10** has a three-layer structure including a transparent conductive layer (a 'first transparent conductive layer'), a reflective layer and a transparent conductive layer (a 'second transparent conductive layer'). In the first electrode having the three-layer structure, the first transparent conductive layer substantially functions as an anode electrode, and the second transparent conductive layer functions to control work function.

[0092] The silver (Ag)-based reflective layer may be a silver (Ag) or silver (Ag) reflective layer. In this regard, the silver alloy may include at least one metal selected from among magnesium (Mg), gold (Au), calcium (Ca), lithium (Li), chromium (Cr), copper (Cu), palladium (Pd), platinum (Pt), nickel (Ni), and aluminum (Al). This silver (Ag)-based reflective layer may have a thickness ranging from about 50 nm to about 100 nm.

[0093] The transparent conductive layer may include a transparent material having a relatively high work function,

such as, for example, a transparent conductive oxide (TCO). Non-limiting examples of the transparent conductive oxide include ITO (Indium Tin Oxide), IZO (Indium Zinc Oxide), ZnO (Zinc Oxide), AZO (Aluminum Zinc Oxide), In₂O₃ (Indium Oxide), SnO₂ (Tin Oxide), and the like, which may be used alone or as a mixture of two or more thereof. This transparent conductive layer may have a thickness ranging from about 2 nm to about 10 nm, for example, a thickness of about 4 nm to 7 nm.

[0094] The first electrode **10** may be formed by a sputtering method, a deposition method, or the like, or any other suitable method available in the art. In one example, it may be formed by a sputtering process using a fine metal mask (FMM).

Second Electrode

[0095] The second electrode **20** may be disposed opposite to the first electrode **10**. The second electrode **20** may include a material having a relatively low work function. This second electrode **20** functions as a cathode that injects electrons into an electron transport region **113b** of a light-emitting unit adjacent thereto.

[0096] The second electrode **20** includes silver (Ag) or a silver-containing material. It may include a silver-containing material. This second electrode **20** may be a (semi)transparent electrode that may provide an organic light-emitting diode device having a top emission-type (or top emission kind) of structure. Examples of the silver-containing material include alloys of silver (Ag) with at least one metal selected from among magnesium (Mg), lithium (Li), calcium (Ca), chromium (Cr), copper (Cu), palladium (Pd), platinum (Pt), nickel (Ni), and aluminum (Al).

[0097] The second electrode **20** may have a thickness ranging from about 5 nm to about 20 nm. In view of a reduction in device thickness as well as electrode supply function, the second electrode **20** may have a thickness ranging from about 10 nm to 15 nm.

[0098] Like the above-described first electrode, the second electrode **20** may be formed by a sputtering method, a deposition method, or the like, or any other suitable method available in the art.

First Light-Emitting Unit

[0099] The first light-emitting unit **110a** is interposed between the first electrode **10** and the second electrode **20**. For example, it may be in direct contact with the first electrode **10**.

[0100] The first light-emitting unit **110a** includes at least one first light-emitting layer **112a** that emits light having a set (e.g., specific) wavelength. If necessary or desired, it may further include any suitable organic layer available in the art. For example, the first light-emitting unit **110a** includes a first hole transport region **111a**, a first light-emitting layer **112a**, and a first electron transport region **113a**.

First Hole Transport Region

[0101] The first hole transport region **111a** is disposed on the first electrode **10**, and functions to transport holes, injected from the first electrode **10**, to the first light-emitting layer **112a**. This first hole transport region **111a** includes one or more selected from a hole injection layer **111a-1** and a

hole transport layer **111a-2**, and if necessary or desired, it may further include any suitable buffer layer available in the art.

[0102] The first hole injection layer **111a-1** may include any suitable hole transport material available in the art, and may, if necessary or desired, include a p-type dopant.

[0103] Non-limiting examples of hole injection materials that may be used include phthalocyanine compounds such as copper phthalocyanine; DNTPD (N,N'-diphenyl-N,N'-bis-[4-(phenyl-m-tolyl-amino)-phenyl]-biphenyl-4,4'-diamine), m-MTDATA (4,4',4''-tris(3-methylphenylphenylamino)triphenylamine), TDATA (4,4,4''-tris(N,N-diphenylamino)triphenylamine), 2-TNATA (4,4',4''-tris{N,-(2-naphthyl)-N-phenylamino}-triphenylamine), PEDOT/PSS (poly(3,4-ethylenedioxythiophene)/poly(4-styrenesulfonate)), PANI/DBSA (polyaniline/dodecylbenzenesulfonic acid), PANI/CSA (polyaniline/camphor sulfonic acid), PANI/PSS (polyaniline/poly(4-styrenesulfonate)), and the like. These may be used alone or as a mixture of two or more thereof.

[0104] The p-dopant may be any suitable dopant available in the art, and is not particularly limited. Examples of the p-dopant include quinone derivatives, such as tetrahydroquinonodimethane (TCNQ), 2,3,5,6-tetrafluoro-tetracyano-1,4-benzoquinonemethane (F4TCNQ) and the like; metal oxides, such as tungsten oxide, molybdenum oxide, rhenium oxide and the like; metal iodides, such as copper iodide, bismuth iodide and the like, hexaazatriphenylene-hexacarbonitrile (HAT-CN), and the like.

[0105] The first hole transport layer **111a-2** may be disposed on the above-described first hole injection layer **111a-1**. For example, the first hole transport layer **111a-2** may be in direct contact with the first hole injection layer **111a-1**. The first hole transport layer **111a-2** may receive holes from the first hole injection layer **111a-1**.

[0106] The first hole transport layer **111a-2** may include any suitable hole transport material available in the art. Non-limiting examples of hole transport materials that may be used include carbazole-based derivatives, such as phenyl carbazole, polyvinyl carbazole and the like; fluorine-based derivatives; triphenylamine-based derivatives, such as TPD (N,N'-bis(3-methylphenyl)-N,N'-diphenyl-[1,1'-biphenyl]-4,4'-diamine), TCTA (4,4',4''-tris(N-carbazolyl)triphenylamine) and the like; NPB (N,N'-di(1-naphthyl)-N,N'-diphenylbenzidine), TAPC (4,4'-cyclohexylidene bis[N,N-bis(4-methylphenyl)benzenamine]), and the like. These may be used alone or as a mixture of two or more thereof. If necessary or desired, the first hole transport layer **111a-2** may include a p-type dopant.

First Light-Emitting Layer

[0107] The first light-emitting layer **112a** is disposed on the first hole transport region **111a**. For example, it is located between the first hole transport region **111a** and the first electron transport region **113a**. This light-emitting layer **112a** may receive holes from the first hole transport region **111a** and receive electrons from the first electron transport region **113a**. The holes and electrons supplied as described above combine to form excitons in the first light-emitting layer **112a**. When the energy level of these excitons changes from an excitation state to a ground state, light having a color corresponding to the changed energy level may be emitted.

[0108] The first light-emitting layer **112a** may emit light having a first wavelength. The light color emitted from the

first light-emitting layer **112a** is not particularly limited, and may vary depending on the material forming the first light-emitting layer **112a**. Examples of the light color include blue, green, red, yellow, white, and the like. This first light-emitting layer **112a** may include materials that emits red, green, blue, yellow and white light colors, and it may be formed using phosphorescent or fluorescent materials.

[0109] In one embodiment, the first light-emitting layer **112a** may include two or more light-emitting layers. These two or more light-emitting layers may emit a light color having the same (e.g., substantially the same) wavelength. In some embodiments, the first light-emitting layer **112a** may include a plurality of layers that emit lights having different wavelengths. For example, it may be provided to include different light-emitting dopants.

[0110] The first light-emitting layer **112a** includes a host, and may optionally further include a dopant. When the first light-emitting layer **112a** includes a host and a dopant, the content of the dopant may range from about 0.01 to about 25 parts by weight, such as, for example, from about 0.01 to about 15 parts by weight, based on 100 parts by weight of the host, but is not limited thereto.

[0111] The host may be any suitable host available in the art, and is not particularly limited. Examples of the host include, but are not limited to, Alq₃ (tris(8-quinolinolato) aluminum), CBP (4,4'-bis(N-carbazolyl)-1,1'-biphenyl), PVK (poly(N-vinylcarbazole), AND (9,10-di(naphthalene-2-yl)anthracene), TCTA (4,4',4''-tris(carbazol-9-yl)-triphenylamine), TPBI(1,3,5-tris(N-phenylbenzimidazole-2-yl) benzene), TBADN (3-tert-butyl-9,10-di(naphth-2-yl) anthracene), DSA (distyrylarylene), E3 or CDBP (4,4'-bis(9-carbazolyl)-2,2'-dimethyl-biphenyl), and the like.

[0112] The dopant may be any suitable dopant available in the art, and is not particularly limited. Such dopants may be classified into fluorescent dopants, and phosphorescent dopants. The phosphorescent dopants may be metal complexes including Ir, Pt, Os, Re, Ti, Zr, Hf, or a combination of two or more thereof, but are not limited thereto.

[0113] Meanwhile, such dopants may be classified into red dopants, green dopants, and blue dopants. Suitable red dopants, green dopants, and blue dopants, available in the art, may be used without particular limitation.

[0114] For example, non-limiting examples of the red dopant include PtOEP (Pt(II) octaethylporphyrin), Ir(piq)₃ (tris(2-phenylisoquinoline)iridium), Btp₂Ir(acac) (bis(2-(2'-benzothienyl)-pyridinato-N,C3')iridium(acetylacetonate)), and the like, which may be used alone or as a mixture of two or more thereof.

[0115] Furthermore, non-limiting examples of the green dopant include Ir(ppy)₃ (tris(2-phenylpyridine)iridium), Ir(ppy)₂(acac) (bis(2-phenylpyridine)(acetylacetonato) iridium(III)), Ir(mppy)₃ (tris(2-(4-tolyl)phenylpyridine) iridium), C545T (10-(2-benzothiazolyl)-1,1,7,7-tetramethyl-2,3,6,7-tetrahydro-1H,5H,11H-[1]benzopyrano[6,7,8-ij]-quinolizin-11-one), and the like, which may be used alone or as a mixture of two or more thereof.

[0116] Furthermore, non-limiting examples of the blue dopant include F₂Irpic (bis[3,5-difluoro-2-(2-pyridyl)phenyl](picolinato)iridium(III)), (F₂ppy)₂Ir(tmd), Ir(dfppz)₃, DPVBi (4,4'-bis(2,2'-diphenylethen-1-yl)biphenyl) DPAVBi (4,4'-bis[4-(diphenylamino)styryl]biphenyl), TBPe (2,5,8,11-tetra-tert-butylperylene), and the like, which may be used alone or as a mixture of two or more thereof.

[0117] The light-emitting layer **112a** may have a single-layer structure including one type (or kind) of material, a single-layer structure including a plurality of different materials, or a multi-layer (at least two-layer) structure having a plurality of layers including different materials. When the light-emitting layer **112a** includes a plurality of layers, the organic light-emitting diode may emit light having various suitable colors. Furthermore, when the light-emitting layer includes a plurality of layers, the driving voltage of the device may increase, but the current value in the organic light-emitting diode device may become constant, and thus the organic light-emitting diode device may have luminous efficiency that is improved by the number of the light-emitting layers.

First Electron Transport Region

[0118] The first electron transport region **113a** is disposed on the first light-emitting layer **112a**, and functions to transport electrons, injected from a charge generation layer **120a** to be described below, to a first light-emitting layer **112a** adjacent thereto.

[0119] The first electron transport region **113a** includes one or more selected from the group consisting of an electron transport layer and an electron injection layer. In one example, the first electron transport region **113a** may include a first electron transport layer, or may include a first electron transport layer and a first electron injection layer.

[0120] The first electron transport layer includes any electron transport material available in the art. It may, if necessary or desired, include an n-type dopant. Non-limiting examples of electron transport materials that may be used include oxazole-based compounds, isoxazole-based compounds, triazole-based compounds, isothiazole-based compounds, oxadiazole-based compounds, thiadiazole-based compounds, perylene-based compounds, pyrene-based compounds, triazine-based compounds, anthracene-based compounds, aluminum complexes (e.g., Alq₃ (tris(8-quinolinolato)-aluminum), BAlq, SALq, and Almq₃), gallium complexes (e.g., Gaq²OPiv, Gaq²OAc, 2(Gaq²)), and the like. These may be used alone or a mixture of two or more thereof.

[0121] The first electron injection layer may be disposed on the above-described first electron transport layer. For example, it may be in direct contact with the first electron transport layer.

[0122] The first electron injection layer may include any suitable electron injection material available in the art. Non-limiting examples of electron injection materials that may be used include LiF, LiQ, NaQ, Li₂O, BaO, NaCl, CsF; lanthanide metals, such as Yb and the like; and metal halides, such as RbCl, RbI, and the like, which may be used alone or a mixture of two or more thereof.

Second Light-Emitting Unit

[0123] The second light-emitting unit **110b** is interposed between the first light-emitting unit **110a** and the second electrode **20**. For example, it may be in direct contact with the second electrode **20**.

[0124] The second light-emitting unit **110b** includes at least one second light-emitting layer **112a** that emits light having a set (e.g., specific) wavelength. If necessary or desired, it may further include any suitable organic layer available in the art. For example, the second light-emitting

unit **110b** includes a second hole transport region **111b**, a second light-emitting layer **112b**, and a second electron transport region **113b**.

Second Hole Transport Region

[0125] The second hole transport region **111b** is disposed on a charge generation layer **120a** to be described below, and functions to transport holes, injected from the charge generation layer **120a**, such as, for example, the p-type charge generation layer **122a**, to an adjacent second light-emitting layer **112b**. This second hole transport region **111b** includes one or more selected from a second hole injection layer **111b-1** and a second hole transport layer **111b-2**, and may, if necessary or desired, further include any suitable buffer layer available in the art.

[0126] The second hole injection layer **111b-1** and the second hole transport layer **111b-2** are not particularly limited, and may include any suitable hole injection material and any suitable hole transport material, respectively, available in the art. If necessary or desired, a p-type dopant may be used. In one example, each of the second hole injection layer **111b-1** and the second hole transport layer **111b-2** may be configured in substantially the same manner as the above-described first hole transport region **111a**.

Second Light-Emitting Layer

[0127] The second light-emitting layer **112b** is disposed on the second hole transport region **111b**. For example, it is located between the second hole transport region **111b** and the second electron transport region **113b**. This second light-emitting layer **112b** may receive holes from the second hole transport region **111b**, and receive electrons from the second electron transport region **113b**. The holes and electrons supplied as described above combine to form excitons in the second light-emitting layer **112b**. When the energy level of these excitons changes from an excitation state to a ground state, light having a color corresponding to the changed energy level may be emitted.

[0128] The second light-emitting layer **112b** may emit light having a second wavelength. The light color emitted from the second light-emitting layer **112b** is not particularly limited, and may vary depending on the material forming the second light-emitting layer **112b**. Examples of the light color include blue, green, red, yellow, white, and the like. This second light-emitting layer **112b** may include materials that emit red, green, blue, yellow and white light colors, and it may be formed using phosphorescent or fluorescent materials.

[0129] In one embodiment, the second light-emitting layer **112b** may include two or more light-emitting layers. These two or more light-emitting layers may emit a light color having the same (e.g., substantially the same) wavelength. In some embodiments, the second light-emitting layer **112b** may include a plurality of layers that emit light having different wavelengths. For example, it may be provided to include different light-emitting dopants.

[0130] According to an exemplary embodiment of the present disclosure, the first light-emitting unit **112a** of the first light-emitting unit **110a** and the second light-emitting unit **112b** of the second light-emitting unit **110b** may be light-emitting layers that emit light having different colors or that emit light having the same (e.g., substantially the same) color. In this case, the colors displayed by the light-emitting

layers **112a** and **112b** may be in complementary color relation. In addition, the color may be selected as a combination of colors capable of displaying white, and these light-emitting layers **112a** and **112b** may include phosphorescent dopants corresponding to selected colors, respectively.

[0131] The second light-emitting layer **112b** is not particularly limited, and it includes a host, and may optionally further include a dopant.

Second Electron Transport Region

[0132] The second electron transport region **113b** is disposed on the second light-emitting layer **112b**, and functions to transport electrons, injected from a second electrode **120** to be described below, to the second light-emitting layer **112b** adjacent thereto.

[0133] The second electron transport region **113b** includes one or more selected from the group consisting of an electron transport layer and an electron injection layer. In one example, the second transport region **113b** may include a second electron transport layer. In another example, it may include a second electron transport layer and a second electron injection layer.

[0134] The second electron transport layer and the second electron injection layer are not particularly limited, and may include any suitable electron transport material and any suitable electron injection material, respectively, available in the art. If necessary or desired, an n-type dopant may be used. In one example, each of the second electron transport layer and the second electron injection layer may be configured in substantially the same manner as the above-described first electron transport region **113a**.

Charge Generation Layer

[0135] The charge generation layer **120a** is interposed between the first light-emitting unit **110a** and the second light-emitting unit **110b**. For example, the charge generation layer **120a** may be located between the first electron transport region **113a** of the first light-emitting unit **110a** and the second hole transport region **111b** of the second light-emitting region **110b**. For example, it may be in direct contact with the first electron injection layer of the first light-emitting unit **110a** and with the second hole injection layer **111b-1** of the second light-emitting unit **110b**.

[0136] The charge generation layer **120a** may include an n-type charge generation layer **121a** and a p-type charge generation layer **122a**. The n-type charge generation layer **121a** and the p-type charge generation **122a** may come into direct contact with each other to form an NP junction. The NP junction enables electrons and holes to be generated concurrently (e.g., simultaneously) between the n-type charge generation layer **121a** and the p-type charge generation layer **122a**. Referring to the exemplary embodiment shown in FIGS. 1-2, the generated electrons are transferred to the first light-emitting unit **110a** among two adjacent light-emitting units through the n-type charge generation layer **121a**, and the generated holes are transferred to the second light-emitting unit **110a** among two adjacent light-emitting units through the p-type charge generation layer **122a**.

[0137] The charge generation layer **120a** may be formed by doping an n-type material and/or a p-type material into an organic material. For example, the n-type charge generation

layer **121a** may be formed by doping an n-type material into an organic material to facilitate electron supply, and the p-type charge generation layer **122a** may be formed by doping a p-type material into an organic material to facilitate hole supply.

[0138] According to an exemplary embodiment of the present disclosure, at least one of the n-type charge generation layer **121a** and the p-type charge generation layer **122a** includes the above-described charge transfer complex compound represented by formula 1.

[0139] The compound of formula 1, included in the n-type charge generation layer **121a**, includes a first metal (M_1) selected from the group consisting of Group 1 metals, Group 2 metals, lanthanides, and actinides, which are metals (M) having a work function of 4.0 eV or less. For example, it includes an iodide of the first metal.

[0140] In addition, the compound of formula 1, included in the p-type charge generation layer **122a**, includes a second metal (M_2) selected from the group consisting of transition metals and post-transition metals, which are metals (M) having a work function of 4.0 eV or less. For example, it includes an iodide of the second metal.

[0141] The compound represented by formula 1 according to the present disclosure may be for the p-type charge generation layer, because it has an excellent ability to generate and transfer holes.

[0142] The charge generation layer **120a** of the present disclosure is not particularly limited with respect to its component, structure, thickness and the like, as long as it includes the compound represented by formula 1. In one example, the charge generation layer **120a** may be either a mono-layer including the compound of formula 1, which is formed by co-depositing a boron compound and a metal halide, or a mono-layer including a mixture of the compound of formula 1 and at least one different material. In some embodiments, the charge generation layer **120a** may be a multi-layer structure having a plurality of layers formed by depositing two or more different materials. In this case, the compound represented by formula 1 may be a host material for forming the n-type charge generation layer **121a** or the p-type charge generation layer **122a**, or may be used as a dopant material.

[0143] When the compound of formula 1 is used as a dopant material for the n-type charge generation layer **121a** or the p-type charge generation layer **122a**, the amount used thereof may be suitably adjusted within any suitable range of doping amount generally used in the art. In one example, the compound represented by formula 1 may be used in an amount of 0.5 to 50 wt %, for example, 0.5 to 20 wt %, based on the total weight of the charge generation layer.

[0144] A material that may be used in combination with the compound of formula 1 to form the charge generation layer **120a** is not limited, and may be any suitable n-type or p-type charge generation material available in the art. This n-type material used may be a nitrate, carbonate, phosphate, quinolate, halide or chalcogenide-based compound containing an alkali metal, an alkaline earth metal or a general metalloid. In one example, the n-type material may be any one selected from the group consisting of Li_2CO_3 , Liq, LiN_3 , Rb_2CO_3 , $AgNO_3$, $Ba(NO_3)_2$, $Mn(NO_3)_2$, $Zn(NO_3)_2$, $CsNO_3$, Cs_2CO_3 , CsF , CsN_3 , CuI , $CuBr_2$, $CuCl_2$, BiI_3 , $BiBr_3$, $BiCl_3$, Te , $YbTe$ and the like. In addition, p-type materials include phthalocyanine compounds, such as cop-

per phthalocyanine, starburst-type (or starburst kind) of amine derivatives, such as TCTA or m-MTDATA, conductive polymers, and the like.

[0145] In addition to the above-described n-type charge generation layer **121a** and p-type charge generation layer **122a**, the charge generation layer **120a** of the present disclosure may, if necessary or desired, further include a third layer.

[0146] For example, the n-type charge generation layer **121a** and p-type charge generation layer **122a** of the charge generation layer **120a** are stacked adjacent to each other, a depletion region may be formed by combination of the electrons and holes generated therein. In this case, as the potential difference applied to the charge generation layer **120a** increase, the depletion region is enlarged. If the depletion region is enlarged, a problem may arise in that a driving voltage for driving the organic light-emitting diode device increases. For this reason, the charge generation **120a** of the present disclosure may further include, between the n-type charge generation layer **121a** and the p-type charge generation layer **122a**, a depletion-preventing layer for preventing (or reducing) the formation of the depletion region. The depletion-preventing layer may include any suitable material available in the art to prevent (or reduce) the formation of the depletion region. In one example, it may include a carbon allotrope, such as carbon nanotubes (CNTs), graphene or the like.

[0147] In addition, the organic light-emitting diode device according to the present disclosure may further include a charge balancing layer, which is capable of controlling the number and speed of charges that move to the first light-emitting unit **110a** and the second light-emitting unit **110b**, on a region adjacent to the charge generation layer **120a**. Namely, because the movement speed of holes is generally higher than the movement speed of electrons, the charge balancing layer may reduce the speed of holes or increase the speed of electrons, thereby achieving the hole-electron balance, with the result that the efficiency of generation of excitons is increased.

[0148] In the present disclosure, the thickness of the charge generation layer **120a** is not particularly limited, and may be suitably adjusted within any suitable range generally used in the art. In one example, it may range from about 5 nm to about 30 nm. When the thickness of the charge generation layer **120a** is in this range, suitable or satisfactory hole transport characteristics and a proper amount of charges can be obtained without substantially increasing the driving voltage.

[0149] The charge generation layer **120a** may be formed using any suitable method available in the art. Examples of the method include, but are not limited to, a vacuum deposition method, a spin coating method, a cast method, a Langmuir-Blodgett (LB) method, an inkjet printing method, a laser printing method, a laser-induced thermal imaging (LITI) method, and the like. For example, the method may be a vacuum deposition method.

[0150] Meanwhile, FIG. 3 is a cross-sectional view schematically showing the structure of an organic light-emitting diode device **200** according to a second exemplary embodiment of the present disclosure.

[0151] In the following description on FIG. 3, contents overlapping with those of FIGS. 1-2 will not be described again, but only differences will be described.

[0152] An exemplary embodiment of the organic light-emitting diode device shown in FIG. 3 includes at least two more (m-1) charge generation layers compared to that shown in FIGS. 1-2.

[0153] For example, the organic light-emitting diode device **200** includes m light-emitting unit **110a**, **110b**, **110m-1** and **110m**, and m-1 charge generation layers **120a**, **120b** and **120m-1**. In this case, m may be an integer of 2 or more. In one example, m may be 2 to 10, for example, 2 to 4, 2 or 3.

[0154] Each of the m-1 charge generation layers **120a**, **120b** and **120m-1** includes one n-type charge generation layer and one p-type charge generation layer. Accordingly, the organic light-emitting diode device **200** including the m-1 charge generation layers includes m-1 n-type charge generation layers and m-1 p-type charge generation layers. The n-type charge generation layers are disposed adjacent to the electron transport regions of them light-emitting units **110a**, **110b**, **110m-1** and **110m**, and the p-type charge generation layers are disposed adjacent to the hole transport regions of them light-emitting units **110a**, **110b**, **110m-1** and **110m**.

[0155] In the present disclosure, the m-1 charge generation layers **120a**, **120b** and **120m-1** may include the same material or different materials. For example, the m-1 charge generation layers **120a**, **120b** and **120m-1** each includes at least one host and at least one dopant. One of the at least one host and dopant may be the compound for the charge generation layer, which is represented by formula 1.

[0156] Them light-emitting units **110a**, **110b**, **110m-1** and **110m** are disposed alternately with the m-1 charge generation layers **120a**, **120b** and **120m-1**. Among these m light-emitting units **110a**, **110b**, **110m-1** and **110m**, two light-emitting units **110a** and **110m** are disposed adjacent to the first electrode **10** and the second electrode **20**, respectively.

[0157] Each of them light-emitting units **110a**, **110b**, **110m-1** and **110m** includes a hole transport region, a light-emitting layer and an electron transport region.

[0158] Each of the m hole transport regions included in the m light-emitting units includes at least one of a hole injection layer and a hole transport layer. For example, the hole transport region may include only the hole injection layer, or include both the hole injection layer and the hole transport layer.

[0159] In addition, each of the m electron transport regions included in the m light-emitting units includes at least one of an electron transport layer and an electron injection layer. In one example, each electron transport region includes only the electron transport layer. In another example, each electron transport region may include both the electron transport layer and the electron injection layer.

[0160] Them light-emitting units **110a** and **110b** may include light emitting layers **112a** and **112b** that emit light having different colors. In some embodiments, these m light-emitting units may also include light emitting layers **112a** and **112b** that emit light having the same (e.g., substantially the same) color. In this case, the colors displayed by the light-emitting layers may be in complementary color relation. In addition, the color may be selected as a combination of colors capable of displaying white, and these light-emitting layers may include phosphorescent dopants corresponding to selected colors, respectively.

[0161] The organic light-emitting diode device of the present disclosure, which includes the above-described con-

figuration, may be provided in a flat panel display device including a transistor. For example, according to the present disclosure, there is provided a flat panel display device including: a transistor including a source electrode, a drain electrode, a gate electrode and an active layer; and the organic light-emitting diode device including the charge generation layer, wherein the first electrode of the organic light-emitting diode device is electrically coupled to (e.g., electrically connected to) one of the source electrode and the drain electrode. For example, the flat panel display device may be an organic light-emitting display device.

[0162] The active layer of the transistor may be selected from various suitable material layers, such as an amorphous silicon layer, a crystalline silicon layer, an organic semiconductor layer, an oxide semiconductor layer, and the like.

[0163] Since the flatpanel display device includes the tandem-type (or tandem kind) of organic light-emitting diode device, it can exhibit effects, such as low driving voltage, improved efficiency, high stability and long lifespan characteristics. Accordingly, this display device has excellent luminous efficiency, and may be advantageously applied to flexible organic light-emitting display devices that have recently attracted a lot of attention in the display field, as well as lighting devices.

[0164] Hereinafter, the present disclosure will be described in further detail with reference to examples. However, these examples are intended to illustrate the present disclosure, and the scope of the present disclosure is not limited to these examples.

Example 1: Fabrication of Organic Light-Emitting Diode Device Formation of Hole Transport Region

[0165] A glass substrate having formed thereon a 15 Ω/cm^2 (120 nm) ITO (Corning) as an anode was cut to a size of 50 mm \times 50 mm \times 0.5 mm, and washed by ultrasonic cleaning for 15 minutes with each of acetone, isopropyl alcohol, and purified water. Next, the glass substrate was irradiated with UV light for 30 minutes, washed by exposure to ozone, and then placed in a vacuum deposition system.

[0166] On the ITO anode, m-TDATA and F4-TCNQ (3 wt %) were co-deposited to form a 20 nm-thick hole injection layer. Next, on the hole injection layer, NPB was deposited to form a 150 nm-thick hole transport layer, thereby forming a hole transport region.

Formation of First Light-Emitting Unit

[0167] On the hole transport region, ADN and DPAVBi (5 wt %) were co-deposited to form a 20 nm-thick light-emitting layer. Next, on the light-emitting layer, Bphen was deposited to form a 30 nm-thick electron transport (ET)-auxiliary light emitting layer, thereby forming a first light-emitting unit.

Formation of Charge Generation Layer

[0168] On the first light-emitting unit, a phenanthroline host and Li (2 wt %) were co-deposited to form a 10 nm-thick n-type charge generation layer. Next, on n-type charge generation layer, a boron-containing compound represented by Formula 8 below and a metal halide (BiI_3 , bismuth iodide) were co-deposited at a weight ratio of 50:50 (1:1), and a silver (Ag)- or tellurium (Te)-based chalcogenide having a 15 nm thickness and a low work function value was formed to be of a p-type, thereby forming a p-type charge generation layer.

genide having a 15 nm thickness and a low work function value was formed to be of a p-type, thereby forming a p-type charge generation layer.

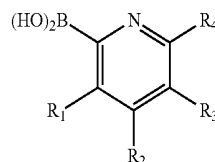

Formula 8

[0169] wherein R_1 to R_4 are each a methyl group.

Formation of Second Light-Emitting Unit

[0170] On the charge generation layer, a 30 nm-thick hole transport (HT)-auxiliary light emitting layer was formed. Next, on the HT-auxiliary light emitting layer, CBP and PYD (15 wt %) were co-deposited to form a 30 nm-thick light-emitting layer. On the light-emitting layer, Bphen was deposited to form a 10 nm-thick ET-auxiliary light emitting layer, thereby forming a second light-emitting unit.

Formation of Electron Transport Region and Second Electrode

[0171] On the second light-emitting unit, Bphen and LiQ (1:1 w/w) were co-deposited to form a 30 nm thick electron transport layer. On the electron transport layer, LiQ was deposited to form a 1 nm thick electron injection layer. Next, on the electron injection layer, Al was deposited to form a 200 nm thick second electrode (cathode), thereby fabricating an organic light-emitting diode device.

Example 2: Fabrication of Organic Light-Emitting Diode Device

[0172] An organic light-emitting diode device of Example 2 was fabricated in substantially the same manner as described in Example 1, except that the charge generation layer was formed using the boron-containing compound and the metal halide at a weight ratio of 20:80.

Comparative Example 1: Fabrication of Organic Light-Emitting Diode Device

[0173] An organic light-emitting diode device of Comparative Example 1 was fabricated in substantially the same manner as described in Example 1, except that the boron-containing compound was not used in the charge generation layer.

Test Example 1: Evaluation of Physical Properties of Organic Light-Emitting Devices

[0174] The driving voltage characteristics of the organic light-emitting diode devices fabricated in Examples 1 and 2 and Comparative Example 1 were measured, and the results of the measurement are shown in FIG. 5.

[0175] The test results indicated that the driving voltages of the organic light-emitting diode devices fabricated in Examples 1 and 2 of the present disclosure were significantly lower than that of the organic light-emitting diode device of Comparative Example 1, while the efficiency characteristics thereof were not reduced (see FIG. 5).

[0176] As described above, the organic light-emitting diode device according to the exemplary embodiment of the present disclosure includes the charge generation layer having an excellent ability to generate and transfer charges. Accordingly, the organic light-emitting diode device including a plurality of stacked light-emitting units may exhibit low driving voltage, high efficiency, and long lifespan characteristics at the same (e.g., substantially the same) time.

[0177] It will be understood that, although the terms “first,” “second,” “third,” etc., may be used herein to describe various elements, components, regions, layers and/or sections, these elements, components, regions, layers and/or sections should not be limited by these terms. These terms are used to distinguish one element, component, region, layer or section from another element, component, region, layer or section. Thus, a first element, component, region, layer or section described below could be termed a second element, component, region, layer or section, without departing from the spirit and scope of the present disclosure.

[0178] Spatially relative terms, such as “beneath,” “below,” “lower,” “under,” “above,” “upper,” and the like, may be used herein for ease of explanation to describe one element or feature’s relationship to another element(s) or feature(s) as illustrated in the figures. It will be understood that the spatially relative terms are intended to encompass different orientations of the device in use or in operation, in addition to the orientation depicted in the figures. For example, if the device in the figures is turned over, elements described as “below” or “beneath” or “under” other elements or features would then be oriented “above” the other elements or features. Thus, the example terms “below” and “under” can encompass both an orientation of above and below. The device may be otherwise oriented (e.g., rotated 90 degrees or at other orientations) and the spatially relative descriptors used herein should be interpreted accordingly.

[0179] It will be understood that when an element or layer is referred to as being “on,” “connected to,” or “coupled to” another element or layer, it can be directly on, connected to, or coupled to the other element or layer, or one or more intervening elements or layers may be present. In addition, it will also be understood that when an element or layer is referred to as being “between” two elements or layers, it can be the only element or layer between the two elements or layers, or one or more intervening elements or layers may also be present.

[0180] The terminology used herein is for the purpose of describing particular embodiments only and is not intended to be limiting of the present disclosure. As used herein, the singular forms “a” and “an” are intended to include the plural forms as well, unless the context clearly indicates otherwise. It will be further understood that the terms “comprises,” “comprising,” “includes,” and “including,” when used in this specification, specify the presence of the stated features, integers, acts, operations, elements, and/or components, but do not preclude the presence or addition of one or more other features, integers, acts, operations, elements, components, and/or groups thereof. As used herein, the term “and/or” includes any and all combinations of one or more of the associated listed items. Expressions such as “at least one of,” when preceding a list of elements, modify the entire list of elements and do not modify the individual elements of the list.

[0181] As used herein, the terms “substantially,” “about,” and similar terms are used as terms of approximation and not as terms of degree, and are intended to account for the inherent deviations in measured or calculated values that would be recognized by those of ordinary skill in the art. Further, the use of “may” when describing embodiments of the present disclosure refers to “one or more embodiments of the present disclosure.” As used herein, the terms “use,” “using,” and “used” may be considered synonymous with the terms “utilize,” “utilizing,” and “utilized,” respectively. Also, the term “exemplary” is intended to refer to an example or illustration.

[0182] Also, any numerical range recited herein is intended to include all sub-ranges of the same numerical precision subsumed within the recited range. For example, a range of “1.0 to 10.0” is intended to include all subranges between (and including) the recited minimum value of 1.0 and the recited maximum value of 10.0, that is, having a minimum value equal to or greater than 1.0 and a maximum value equal to or less than 10.0, such as, for example, 2.4 to 7.6. Any maximum numerical limitation recited herein is intended to include all lower numerical limitations subsumed therein, and any minimum numerical limitation recited in this specification is intended to include all higher numerical limitations subsumed therein. Accordingly, Applicant reserves the right to amend this specification, including the claims, to expressly recite any sub-range subsumed within the ranges expressly recited herein.

[0183] While the exemplary embodiments of the present disclosure have been described with reference to the accompanying drawings, it will be appreciated by a person having ordinary knowledge in the art to which the present disclosure pertains that the present disclosure may be practiced in other specific forms without changing the technical spirit and essential feature of the present disclosure. Therefore, it should be understood that the above-described embodiments are illustrative but not limitative in all aspects.

What is claimed is:

1. An organic light-emitting diode device comprising:
 - a first electrode;
 - a second electrode disposed opposite to the first electrode;
 - m light-emitting units (where m is an integer of 2 or more) disposed between the first electrode and the second electrode, and comprising at least one light-emitting layer; and
 - m-1 charge generation layers each interposed between two adjacent light-emitting units of the m light-emitting units;
 wherein at least one of the m-1 charge generation layers comprises a compound represented by Formula 1 below:



wherein:

- M is a metal selected from the group consisting of Group 1 metals, Group 2 metals, transition metals, post-transition metals, lanthanides, and actinides, which have a work function of 4.0 eV or less;
- X is a halogen element selected from the group consisting of F, Cl, Br, and I;
- a is a natural number ranging from 1 to 4; and
- Y_1 and Y_2 are the same or different, and are each independently one or more selected from the group consisting of a halogen, a hydroxyl group, a nitro group, a

cyano group, an amine group, a C₁-C₄₀ alkyl group, a C₆-C₄₀ aryl group, and a 5-to 40-membered heteroaryl group, or they may be bonded to an adjacent group to form a condensed ring, provided that at least one of Y₁ and Y₂ is a C₆-C₄₀ aryl group or a 5- to 40-membered heteroaryl group; and

wherein the alkyl group, the aryl group, and the heteroaryl group are each unsubstituted or substituted with one or more substituents selected from the group consisting of a halogen, a cyano group, a nitro group, a C₁-C₄₀ alkyl group, a C₆-C₄₀ aryl group, a 5- to 40-membered heteroaryl group, a C₆-C₄₀ aryloxy group, a C₆-C₄₀ arylphosphine oxide group, and a C₆-C₄₀ arylamine group, and the substituents may be the same or different if they are plural in number.

2. The organic light-emitting diode device of claim 1, wherein the compound represented by formula 1 is a charge-transfer (CT) complex comprising a boron-containing compound and a metal halide.

3. The organic light-emitting diode device of claim 2, wherein a content ratio between the boron-containing compound and the metal halide is 0.5-50: 50-95.5 by weight.

4. The organic light-emitting diode device of claim 1, wherein the compound represented by formula 1 is bonded to adjacent compounds of formula 1 to form a cluster, and the cluster comprises at least one heterocyclic ring containing the boron and the metal (M).

5. The organic light-emitting diode device of claim 1, wherein each of the m-1 charge generation layers comprises at least one host and at least one dopant, and one of the at least one host and at least one dopant is the compound represented by formula 1.

6. The organic light-emitting diode device of claim 1, wherein the m light-emitting units are disposed alternately with the m-1 charge generation layers, and two light-emitting units of the m light-emitting units are disposed adjacent to the first electrode and the second electrode, respectively.

7. The organic light-emitting diode device of claim 1, wherein:

each of the m light-emitting units comprises a hole transport region, a light-emitting layer, and an electron transport region;

the hole transport region comprises at least one of a hole injection layer and a hole transport layer; and

the electron transport region comprises at least one of an electron transport layer and an electron transport layer.

8. The organic light-emitting diode device of claim 1, wherein:

each of the m-1 charge generation layers comprises an n-type charge generation layer and a p-type charge generation layer;

the n-type charge generation layer is disposed adjacent to the electron transport region of each of the m light-emitting units; and

the p-type charge generation layer is disposed adjacent to the hole transport region of each of the m light-emitting units.

9. The organic light-emitting diode device of claim 8, wherein the n-type charge generation layer comprises a metal selected from the group consisting of Group 1 metals, Group 2 metals, lanthanides, and actinides, which have a work function of 4.0 eV or less.

10. The organic light-emitting diode device of claim 8, wherein the p-type charge generation layer comprises a metal selected from the group consisting of transition metals and post-transition metals, which have a work function of 4.0 eV or less.

11. A compound for a charge generation layer, comprising:

at least one boron-containing compound; and

at least one metal halide containing a metal having a work function of 4.0 eV or less;

wherein the boron (B) of the boron-containing compound and the metal (M) of the metal halide are bonded to each other by a one-electron sigma bond.

12. The compound of claim 11, wherein a bonding value between the metal (M) and the boron (B), which is measured by X-ray photoelectron spectrometry (XPS), ranges from 180 to 290 eV.

13. The compound of claim 11, wherein the compound is represented by Formula 1 below:



wherein:

M is a metal selected from the group consisting of Group 1 metals, Group 2 metals, transition metals, post-transition metals, lanthanides, and actinides, which have a work function of 4.0 eV or less;

X is a halogen element selected from the group consisting of F, Cl, Br, and I;

a is a natural number ranging from 1 to 4; and

Y₁ and Y₂ are the same or different, and are each independently one or more selected from the group consisting of a halogen, a hydroxyl group, a nitro group, a cyano group, an amine group, a C₁-C₄₀ alkyl group, a C₆-C₄₀ aryl group, and a 5-to 40-membered heteroaryl group, or they may be bonded to an adjacent group to form a condensed ring, provided that at least one of Y₁ and Y₂ is a C₆-C₄₀ aryl group or a 5- to 40-membered heteroaryl group; and

wherein the alkyl group, the aryl group, and the heteroaryl group are each unsubstituted or substituted with one or more substituents selected from the group consisting of a halogen, a cyano group, a nitro group, a C₁-C₄₀ alkyl group, a C₆-C₄₀ aryl group, a 5- to 40-membered heteroaryl group, a C₆-C₄₀ aryloxy group, a C₆-C₄₀ arylphosphine oxide group, and a C₆-C₄₀ arylamine group, and the substituents may be the same or different if they are plural in number.

14. The compound of claim 11, wherein the metal halide is a metal iodide.

15. The compound of claim 11, wherein the compound is used for an n-type charge generation layer, a p-type charge generation layer, or both.

16. The compound of claim 15, wherein the n-type charge generation layer comprises a metal selected from the group consisting of Group 1 metals, Group 2 metals, lanthanides, and actinides, which have a work function of 4.0 eV or less.

17. The compound of claim 15, wherein the p-type charge generation layer comprises a metal selected from the group consisting of transition metals and post-transition metals, which have a work function of 4.0 eV or less.

18. The compound of claim 11, wherein the compound is a charge-transfer (CT) complex comprising a boron-containing compound and a metal halide.

19. The compound of claim **18**, wherein a content ratio between the boron-containing compound and the metal halide is 0.5-50: 50-95.5 by weight.

20. The compound of claim **13**, wherein the compound represented by formula 1 is bonded to adjacent compounds of formula 1 to form a cluster, and the cluster comprises at least one heterocyclic ring containing the boron and the metal (M).

* * * * *

专利名称(译)	其中包括有机发光二极管器件和用于电荷产生层的化合物		
公开(公告)号	US20190288212A1	公开(公告)日	2019-09-19
申请号	US16/206969	申请日	2018-11-30
[标]申请(专利权)人(译)	三星显示有限公司		
申请(专利权)人(译)	三星DISPLAY CO. , LTD.		
当前申请(专利权)人(译)	三星DISPLAY CO. , LTD.		
[标]发明人	CHO YOONHYEUNG JANG HYUNGSEOK KIM DONGCHAN KIM WONJONG MOON JIYOUNG PARK YEONGRONG SEO DONGKYU LEE JIHYE		
发明人	CHO, YOONHYEUNG JANG, HYUNGSEOK KIM, DONGCHAN KIM, WONJONG MOON, JIYOUNG PARK, YEONGRONG SEO, DONGKYU YEO, MYUNGCHUL LEE, JIHYE		
IPC分类号	H01L51/00 C07F5/02		
CPC分类号	H01L51/0051 H01L51/5044 H01L51/008 C07F5/025 H01L51/5278 H01L51/50 H01L51/52 H01L51/0067		
优先权	1020180029112 2018-03-13 KR		
外部链接	Espacenet USPTO		

摘要(译)

公开了一种有机发光二极管装置，包括：第一电极；第二电极，与第一电极相对设置；m个发光单元（m为2或更大的整数）设置在第一电极和第二电极之间，并包括至少一个发光层；每个插入在m个发光单元的两个相邻发光单元之间的m-1个电荷产生层；其中至少一个m-1电荷产生层包括用于电荷产生层的化合物，其包括通过单电子σ键与金属卤化物键合的含硼化合物。

100

